

DA VINCI, the new card lock from VingCard offers the very best in contemporary design and security technology in combination with extensive, user identifiable, feature packages for maximum operational benefits and guest convenience.



DA VINCI by VingCard is a self contained, battery operated electronic door lock for your guestrooms and perimeter areas. It combines elegance and design with security and safety. The modularity in both hardware and software allows for individual design and customisation of features and functionality.

DA VINCI operates on both smartcard and magstripe keycards and is managed by powerful windows software designed for stand alone use or for integration with PMS and POS systems. In addition it is backed up by exclusive world wide warranty and service programs that will guarantee cost efficient operations and protect your investment in your guests' comfort, safety and security.



FEATURES

- ::Exclusive contemporary design
- ::Innovative modular concept
- ::Option of smartcard and magstripe technology
- ::Concealed Life Safety Cylinder option
- ::Unique electronic cylinder surveillance
- ::Ergonomic upsert reader
- ::Easily accessible service modules
- ::Enhanced climate resistance
- ::Palm sized LockLink with user-friendly Windows CE™ and wireless communication
- ::Wide selection of handles and hardware configurations

- **DA VINCI**
by VingCard
- vision
by VingCard
- 2100 PLUS
by VingCard
- Original
by VingCard
- KEYCARDS
by VingCard
- Accessories
by VingCard
- SERVICE
by VingCard

Ansi

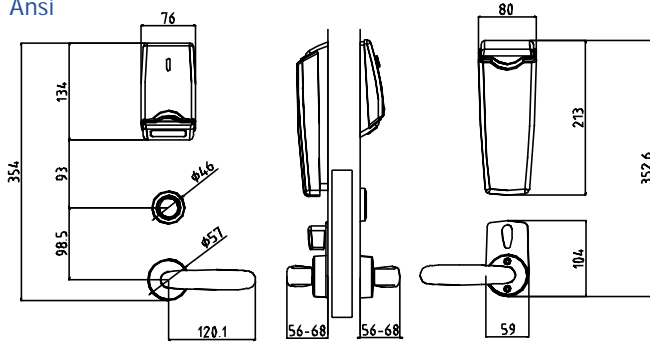

Ansi

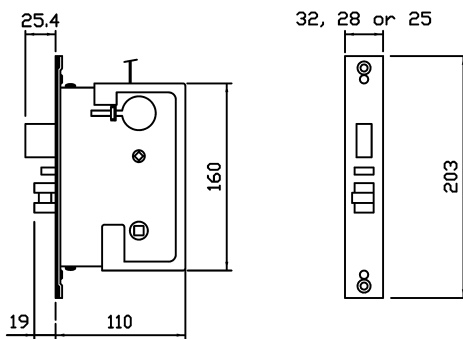

Euro

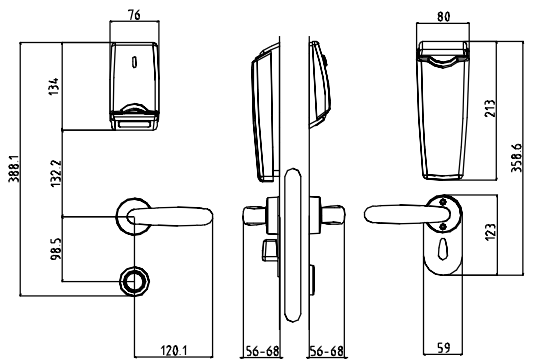

Euro

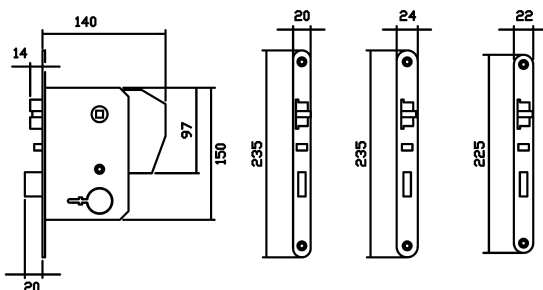

Technical specifications, series

Power supply:	6 AA Alkaline batteries
Battery lifetime:	2-3 years with normal operation and climate
Access media:	Keycard: Magnetic stripe or smart card
Operation indication:	3 coloured LED
Emergency override:	Electronic and mechanical
Mechanical Cylinder:	6 or 7 pin high security pin tumbler cylinder
Cylinder options:	4 different security levels and concealed option
Lock programmer:	Palm PC with CPU dockingstation and Win CE software
Audit trail event memory:	Depending on SW settings, minimum 200
Audit trail download:	Wire or IR
Locking mechanism:	Electro mechanical locking bar located inside the lockcase
Lockcase:	Available in ANSI, Euro, Japan and Pacific standards
Latch type:	3 piece 19mm (3/4 inch) anti-friction latch
Deadbolt:	Case hardened 25,4mm (1 inch) operated by thumbturn from inside
Escutcheons:	All brass
Finishes:	Available in a range of chrome, brass and bronze finishes
Handle type:	Self lubricating all brass handle with internal retraction spring
Handle options:	6 custom designed handles available in all finishes
Extended handle options:	Yes, compliant with standard handle specifications
Retrofit package:	Multi-Brand retrofit kit for all manufacturers and models
Mounting:	Concealed assembly and mounting screws